

Sample Daily Checklists for Powered Industrial Trucks

Depicted below are the major types of industrial trucks and some of the most common variations. The drawings of the trucks depicted below are intended to represent the typical configuration of trucks for each type. They do not include all available options, attachments or configurations.

Electric Motor Powered Industrial Trucks

 <p>A line drawing of a standup end control rider forklift. It features a vertical mast, a seat, and a steering wheel. The operator stands on a platform.</p>	 <p>A line drawing of a sitdown rider forklift. It has a seat and a steering wheel. The operator sits on the truck.</p>	 <p>A line drawing of a narrow aisle reach forklift. It has a long, narrow mast and a seat. The operator sits on the truck.</p>
 <p>A line drawing of a narrow aisle high lift straddle forklift. It has a high mast and a seat. The operator sits on the truck.</p>	 <p>A line drawing of a narrow aisle order picker. It has a high mast and a seat. The operator sits on the truck.</p>	 <p>A line drawing of a narrow aisle sideloader platform. It has a high mast and a seat. The operator sits on the truck.</p>
 <p>A line drawing of a narrow aisle sideloader high lift pallet. It has a high mast and a seat. The operator sits on the truck.</p>	 <p>A line drawing of a narrow aisle turret. It has a high mast and a seat. The operator sits on the truck.</p>	 <p>A line drawing of a narrow aisle low lift platform. It has a low mast and a seat. The operator sits on the truck.</p>
 <p>A line drawing of a stacker pallet. It has a low mast and a seat. The operator sits on the truck.</p>	 <p>A line drawing of a walkie platform low lift. It has a low mast and a seat. The operator sits on the truck.</p>	 <p>A line drawing of a walkie pallet low lift. It has a low mast and a seat. The operator sits on the truck.</p>

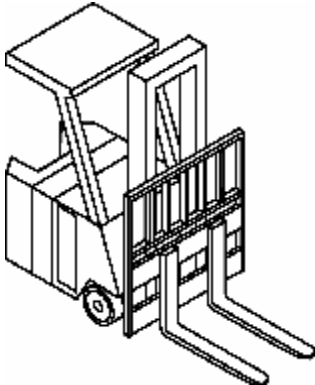
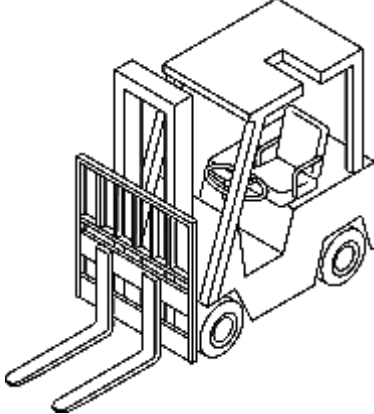
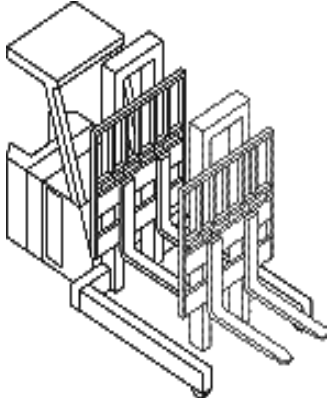
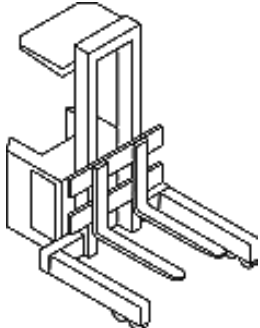
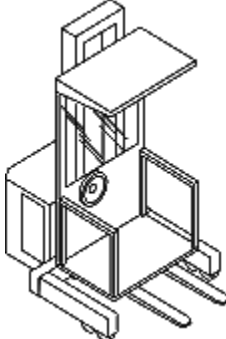
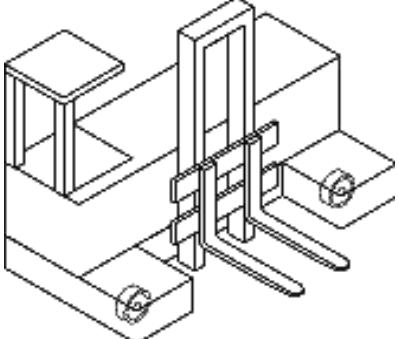
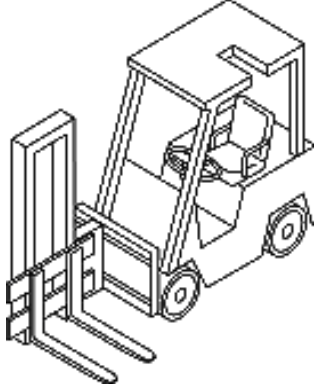
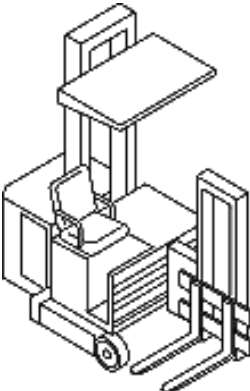
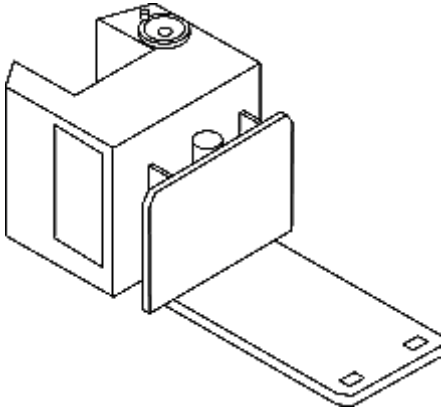
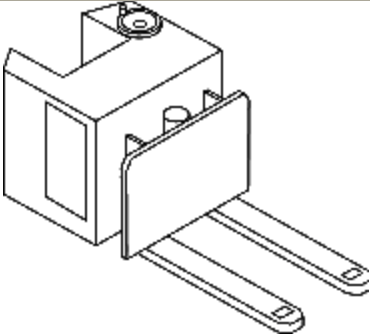
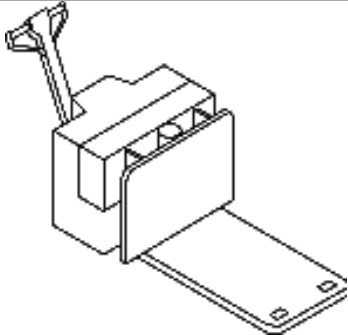
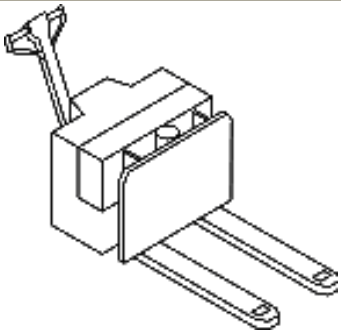
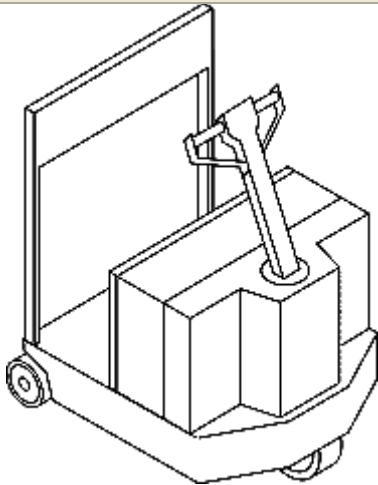

Tractor Walkie/Rider

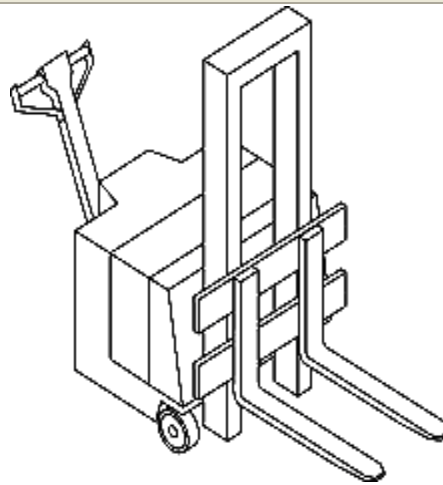

Walkie Pallet High Lift

Internal Combustion Engine Powered Industrial Trucks - Gas/LPG/Diesel

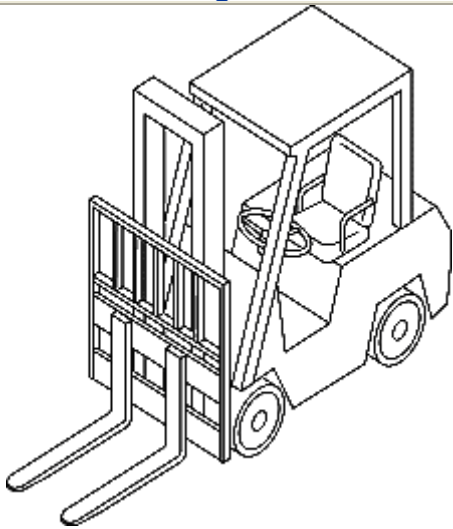

Counterbalanced Forklift Gas/LPG Cushion Tire

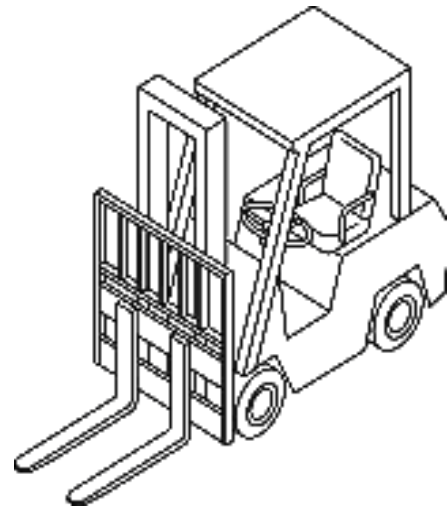

Counterbalanced Forklift Gas/LPG/Diesel Pneumatic Tire

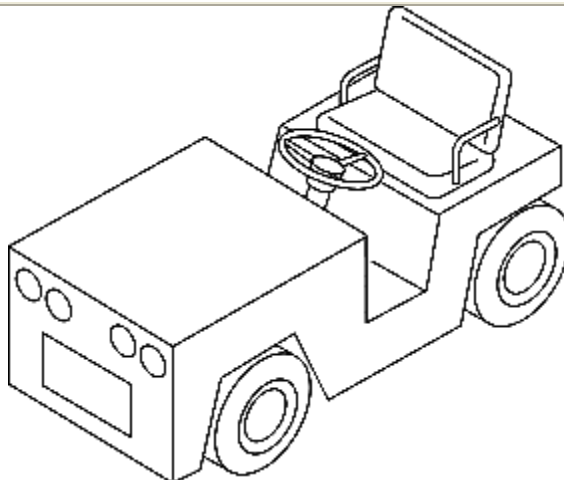

Tow Tractor Gas/LPG/Diesel

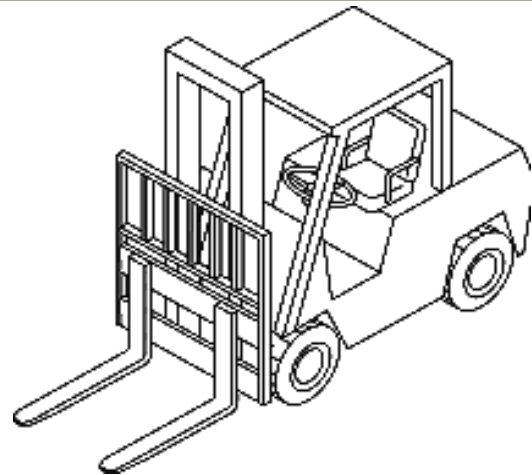

Rough Terrain Forklift Gas/LPG/Diesel Vertical Mast

Daily checklists for each type of industrial truck are available from the truck manufacturer. You may choose to use a checklist for each type of industrial truck in your workplace or compile one that can be used for any type of truck.

Refer to the owner's manual, specifications and manufacturer's recommendations to modify the checklist for trucks being operated in your workplace. Below are sample checklists for internal combustion and electric trucks. These lists can be modified to suit your workplace needs.

Operator's Daily Checklist - Internal Combustion Engine Industrial Truck - Gas/LPG/Diesel Truck

Record of Fuel Added

Date		Operator		Fuel	
Truck#		Model#		Engine Oil	
Department		Serial#		Radiator Coolant	
Shift		Hour Meter		Hydraulic Oil	

SAFETY AND OPERATIONAL CHECKS (PRIOR TO EACH SHIFT)

Have a **qualified** mechanic correct all problems.

Engine Off Checks	OK	Maintenance
Leaks – Fuel, Hydraulic Oil, Engine Oil or Radiator Coolant		
Tires – Condition and Pressure		
Forks, Top Clip Retaining Pin and Heel – Check Condition		
Load Backrest – Securely Attached		
Hydraulic Hoses, Mast Chains, Cables and Stops – Check Visually		
Overhead Guard – Attached		
Finger Guards – Attached		
Propane Tank (LP Gas Truck) – Rust Corrosion, Damage		
Safety Warnings – Attached (Refer to Parts Manual for Location)		
Battery – Check Water/Electrolyte Level and Charge		
All Engine Belts – Check Visually		
Hydraulic Fluid Level – Check Level		
Engine Oil Level – Dipstick		
Transmission Fluid Level – Dipstick		
Engine Air Cleaner – Squeeze Rubber Dirt Trap or Check the Restriction Alarm (if equipped)		
Fuel Sedimentor (Diesel)		
Radiator Coolant – Check Level		
Operator's Manual – In Container		
Nameplate – Attached and Information Matches Model, Serial Number and Attachments		
Seat Belt – Functioning Smoothly		
Hood Latch – Adjusted and Securely Fastened		
Brake Fluid – Check Level		
Engine On Checks – Unusual Noises Must Be Investigated Immediately	OK	Maintenance
Accelerator or Direction Control Pedal – Functioning Smoothly		
Service Brake – Functioning Smoothly		
Parking Brake – Functioning Smoothly		
Steering Operation – Functioning Smoothly		
Drive Control – Forward/Reverse – Functioning Smoothly		
Tilt Control – Forward and Back – Functioning Smoothly		
Hoist and Lowering Control – Functioning Smoothly		
Attachment Control – Operation		
Horn and Lights – Functioning		
Cab (if equipped) – Heater, Defroster, Wipers – Functioning		
Gauges: Ammeter, Engine Oil Pressure, Hour Meter, Fuel Level, Temperature, Instrument Monitors – Functioning		

Operator's Daily Checklist - Electric Industrial Truck

Record of Fluid Added

Date		Operator		Battery Water	
Truck#		Model#		Hydraulic Oil	
Department		Serial#			
Shift		Drive Hour Meter Reading		Hoist Hour Meter Reading	

SAFETY AND OPERATIONAL CHECKS (PRIOR TO EACH SHIFT)

Have a **qualified** mechanic correct all problems.

Motor Off Checks	OK	Maintenance
Leaks – Hydraulic Oil, Battery		
Tires – Condition and Pressure		
Forks, Top Clip Retaining Pin and Heel -- Condition		
Load Backrest Extension – Attached		
Hydraulic Hoses, Mast Chains, Cables & Stops – Check Visually		
Finger Guards – Attached		
Overhead Guard – Attached		
Safety Warnings – Attached (Refer to Parts Manual for Location)		
Battery – Water/Electrolyte Level and Charge		
Hydraulic Fluid Level – Dipstick		
Transmission Fluid Level – Dipstick		
Operator's Manual in Container		
Capacity Plate Attached – Information Matches Model, Serial Number and Attachments		
Battery Restraint System – Adjust and Fasten		
Operator Protection		
Sitdown Truck - Seat Belt – Functioning Smoothly		
Man-up Truck – Fall protection/Restraining means - Functioning		
Brake Fluid – Check level		
Motor On Checks (Unusual Noises Must Be Investigated Immediately)	OK	Maintenance
Accelerator Linkage – Functioning Smoothly		
Parking Brake – Functioning Smoothly		
Service Brake – Functioning Smoothly		
Steering Operation – Functioning Smoothly		
Drive Control – Forward/Reverse – Functioning Smoothly		
Tilt Control – Forward and Back – Functioning Smoothly		
Hoist and Lowering Control – Functioning Smoothly		
Attachment Control – Operation		
Horn – Functioning		
Lights & Alarms (where present) – Functioning		
Hour Meter – Functioning		
Battery Discharge Indicator – Functioning		
Instrument Monitors – Functioning		

ALL OPERATORS MUST BE TRAINED AND EVALUATED ON THE TYPES OF INDUSTRIAL TRUCKS AND ATTACHMENTS THEY WILL BE OPERATING.